

SIMCA 900-1000

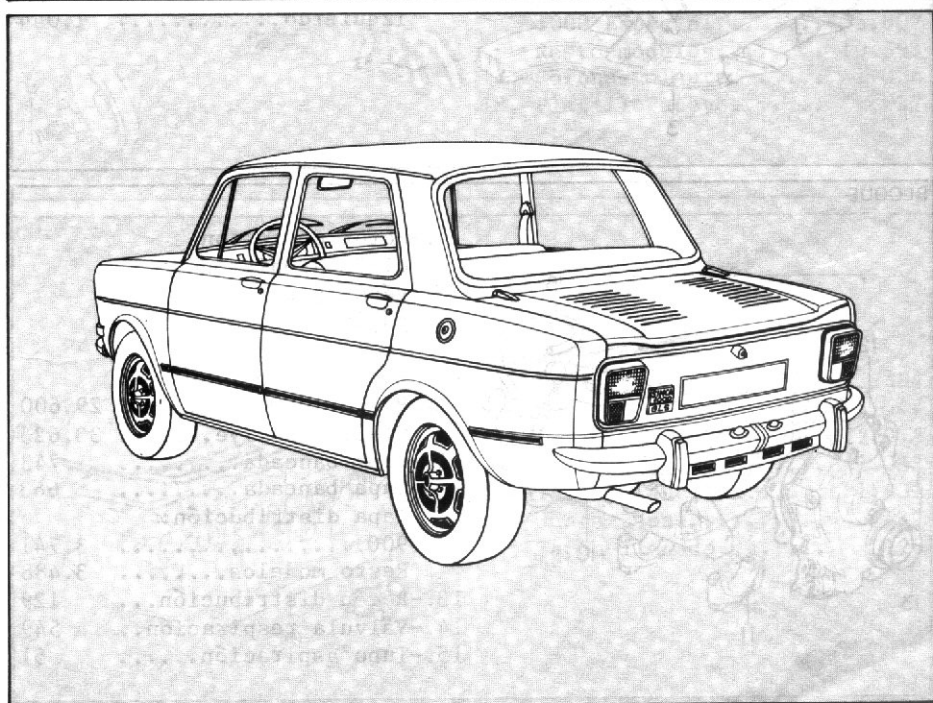

MOTOR

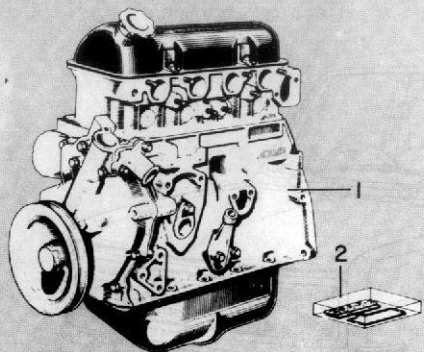

- 1.-Motor cto. sin arranque ni cambio:
Véase precio en página 64 bis.
- 2.-Juego juntas:
900 - 1000..... 972
GT-Esp.-Rallye..... 1.333

SOPORTES

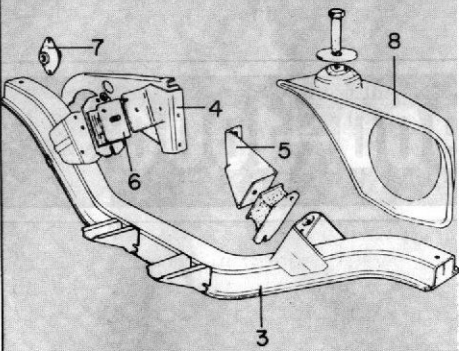

- 3.-Travesaño suspensión. 7.213
- 4.-Soporte izdo..... 1.962
- 5.-Soporte dcho..... 720
- 6.-Taco suspensión..... 490
- 7.-Silentblock..... 1.105
- 8.-Soporte cambio:
Derecho..... 1.044
Izquierdo..... 1.044

BLOQUE

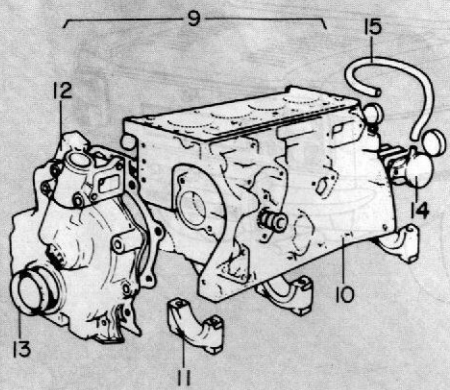

- 9.-Motor corto con cigüeñal-pistones
Véase precio en página 64 bis.
- 10.-Bloque motor:
900 - 1000..... 29.600
GT-Esp.-Rallye..... 33.625
- 11.-Tapa bancada..... 743
Tapa bancada..... 663
- 12.-Tapa distribución:
900..... 3.741
Resto modelos..... 3.488
- 13.-Retén distribución... 129
- 14.-Válvula respiración.. 549
- 15.-Tubo aspiración..... 51

BIELAS Y PISTONES

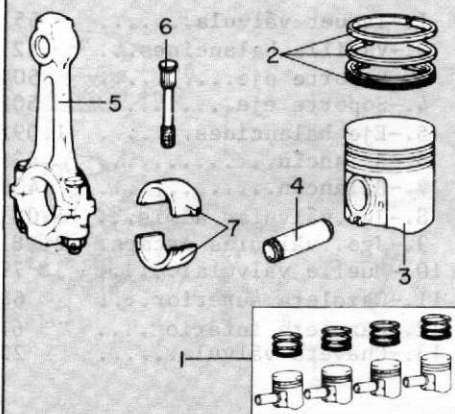

1.-Equipo motor:	
1000.....	8.442
1000 Rallye.....	10.602
2.-Jgo.segmentos (lp.):	
900 - 1000.....	647
GT-Esp.-Rallye.....	666
3.-Pistón:	
900.....	1.079
1000.....	1.128
GT-Esp.-Rallye.....	1.486
4.-Bulón pistón.....	469
5.-Biela motor.....	3.821
6.-Tornillo biela.....	133
7.-Casquillo biela.....	133

CIGÜEÑAL

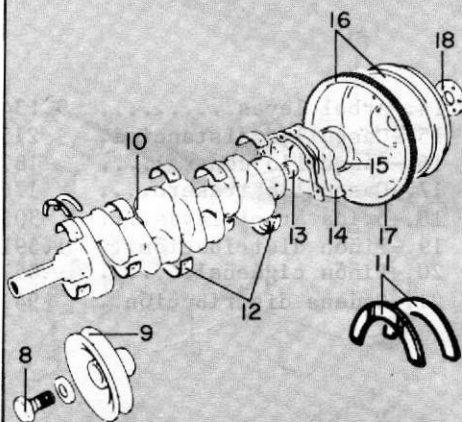

8.-Tornillo polea.....	174
9.-Polea cigüeñal.....	4.754
10.-Cigüeñal.....	20.883
11.-Juego axiales.....	158
12.-Juego cojinetes.....	1.325
13.-Cojinete cigüeñal....	355
14.-Tapa trasera.....	619
15.-Retén trasero.....	2.917
16.-Volante con corona:	
1000 Especial.....	5.807
Resto modelos.....	10.593
17.-Corona volante.....	1.086
18.-Platillo apoyo.....	32

CULATA

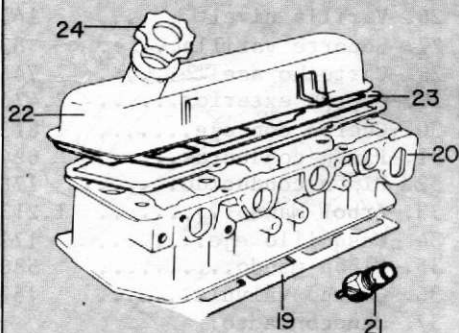

19.-Junta culata:	
Espesor 1,2.....	484
Espesor 2,2.....	547
20.-Culata motor.....	22.975
21.-Termistore.....	1.023
22.-Tapa balancines.....	1.432
23.-Junta tapa.....	132
24.-Tapón llenado.....	126

DISTRIBUCION

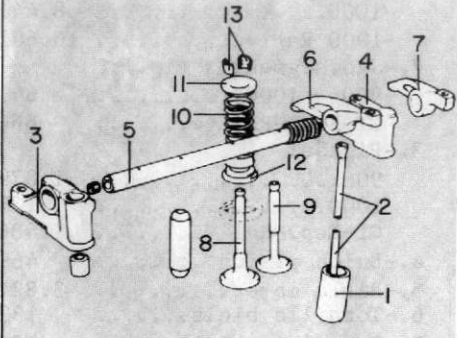

1.-Taquet válvula.....	555
2.-Varilla balancines...	121
3.-Soporte eje.....	508
4.-Soporte eje.....	508
5.-Eje balancines.....	1.092
6.-Balancín.....	438
7.-Balancín.....	438
8.-Jgo.válvulas admis...	1.085
9.-Jgo. válvulas escape.	2.281
10.-Muelle válvula.....	79
11.-Cazoleta superior....	68
12.-Cazoleta inferior....	61
13.-Chaveta válvula.....	22

DISTRIBUCION

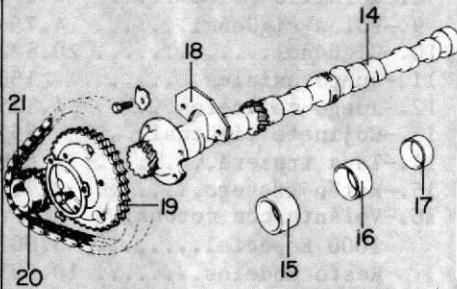

14.-Arbol levas.....	9.134
15.-Casquillo distanciad.	215
16.-Casquillo central....	187
17.-Casquillo trasero....	176
18.-Brida árbol levas....	503
19.-Piñón distribución...	1.591
20.-Piñón cigüeñal.....	857
21.-Cadena distribución..	941

LUBRICACION

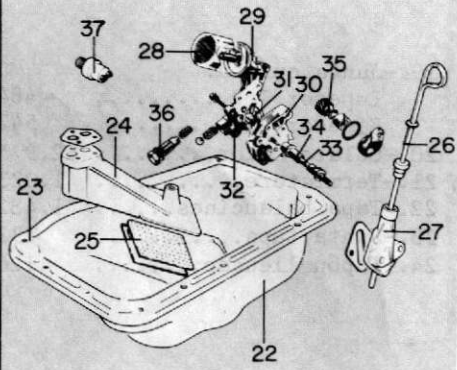

22.-Cárter aceite.....	970
23.-Junta cárter.....	112
24.-Filtro aspiración....	1.230
25.-Tamiz filtro.....	79
26.-Varilla nivel.....	147
27.-Soporte varilla.....	83
28.-Cartucho aceite.....	745
29.-Cuerpo exterior.....	2.476
30.-Cuerpo con eje.....	1.813
31.-Piñón conductor.....	624
32.-Piñón conducido.....	178
33.-Arbol mando.....	1.213
34.-Casquillo eje.....	172
35.-Piñón mando.....	586
36.-Cuerpo válvula.....	152
37.-Manocontacto:	
900 - 1000.....	1.187
GT - Rallye.....	623

ALIMENTACION

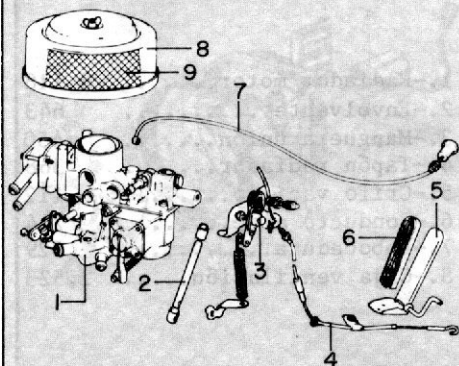

1.-Carburador:	
Solex (d/1975).....	16.086
Solex (h/1975).....	8.506
Solex 1000-GLE.....	11.651
Weber 1000-GLE.....	7.100
2.-Bieleta mando.....	164
3.-Palanca retorno:	
Rallye.....	837
Resto modelos.....	158
4.-Cable sin funda.....	80
5.-Pedal acelerador.....	444
6.-Goma pedal.....	55
7.-Tirador starter.....	507
8.-Conjunto. filtro.....	2.550
9.-Elemento filtro.....	551

ALIMENTACION

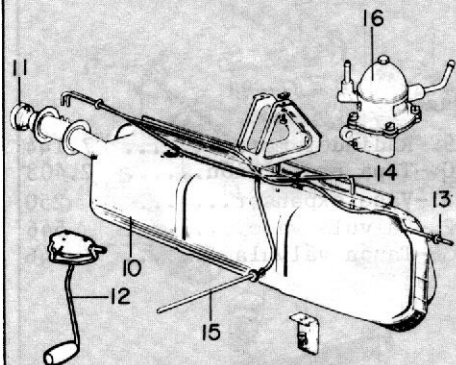

10.-Depósito gasolina....	7.873
11.-Tapón con llave.....	1.112
12.-Aforador.....	1.359
13.-Tubo respiradero.....	59
14.-Tubo respiradero.....	13
15.-Tubo alimentación....	160
16.-Bomba gasolina.....	2.016

COLECTORES Y ESCAPE

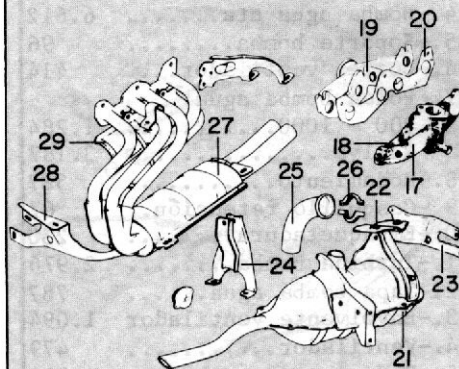

17.-Colector admisión:	
900.....	4.485
900-Esp.-Rallye.....	4.568
1000.....	4.932
Rallye (d/1978).....	6.106
18.-Junta admisión.....	21
19.-Colector escape.....	2.942
20.-Junta escape.....	116
21.-Conjunto silencioso..	2.113
22.-Chapa protección.....	718
23.-Soporte silencioso...	3.113
24.-Patilla silencioso...	597
25.-Tubo salida.....	319
26.-Abrazadera.....	128
27.-Conjunto silencioso..	11.390
28.-Soporte silencioso...	838
29.-Chapa protección.....	216

REFRIGERACION

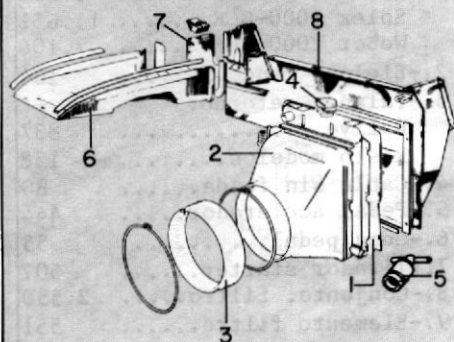

1.-Radiador motor.....	8.118
2.-Envolvente.....	643
3.-Manguera unión.....	450
4.-Tapón radiador.....	368
5.-Grifo vaciado.....	112
6.-Conducto aire.....	764
7.-Emboadura.....	329
8.-Caja ventilación.....	2.523

REFRIGERACION

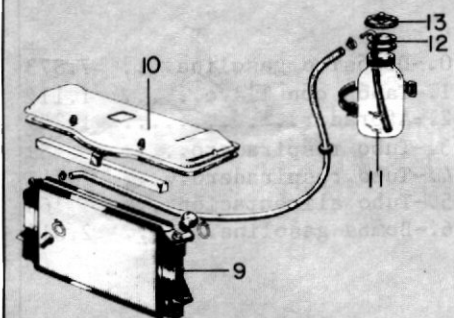

9.-Radiador motor.....	7.144
10.-Tapa protección.....	2.403
11.-Vaso expansor.....	250
12.-Válvula vaso.....	546
13.-Tapón válvula.....	46

REFRIGERACION

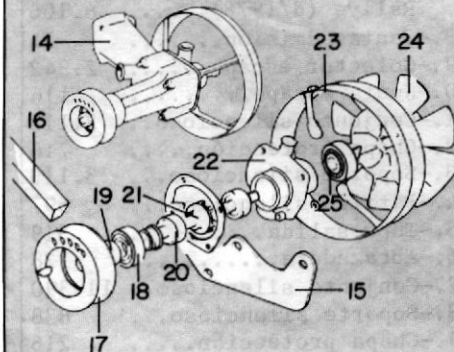

14.-Bomba agua cta.....	6.612
15.-Soporte bomba.....	96
16.-Correa ventilador.....	414
17.-Polea bomba agua:	
900 - 1000.....	1.284
Rallye.....	3.187
18.-Rodamiento.....	587
19.-Casquillo retención..	67
20.-Empaquetadura.....	230
21.-Turbina bomba.....	2.976
22.-Tapa bomba agua.....	787
23.-Envolvente ventilador	1.094
24.-Ventilador.....	479
25.-Rodamiento.....	534

REFRIGERACION

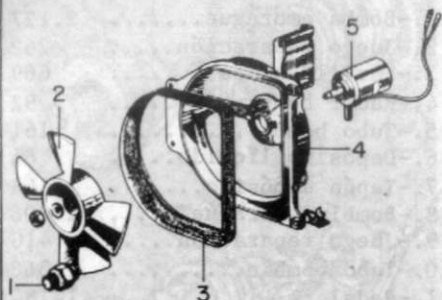

1.-Termocontacto.....	2.231
2.-Ventilador.....	212
3.-Goma contorno.....	180
4.-Carcasa.....	1.286
5.-Electroventilador....	2.890

REFRIGERACION

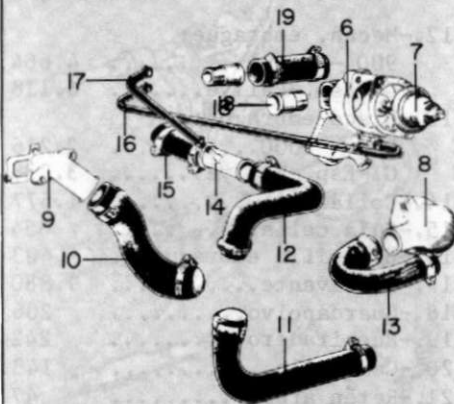

6.-Cuerpo salida.....	1.420
7.-Termostato:	
900 - 1000.....	848
GT-Esp.-Rallye.....	659
8.-Codo salida:	
900 - 1000.....	183
GT-Esp.-Rallye.....	148
9.-Codo entrada.....	194
10.-Manguito.....	382
11.-Manguito bomba.....	291
12.-Manguito salida.....	218
13.-Manguito retorno.....	168
14.-Tubo entre manguitos.	102
15.-Manguito salida.....	191
16.-Manguito entrada.....	139
17.-Manguito entrada.....	123
18.-Racor colector.....	143
19.-Manguito salida.....	58

REFRIGERACION

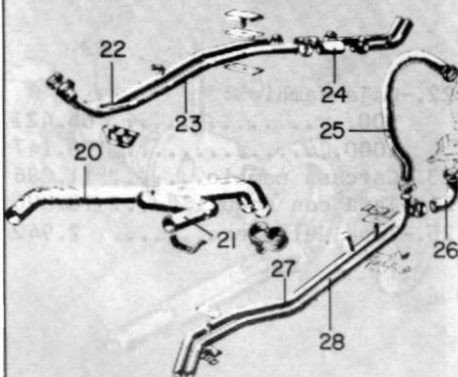

20.-Manguito inferior....	1.638
21.-Manguito superior....	957
22.-Tubo enfriamiento....	4.316
23.-Tubo llegada.....	4.316
24.-Manguito.....	126
25.-Manguito salida.....	256
26.-Manguito entrada.....	347
27.-Tubo dcho.....	7.207
28.-Tubo izdo.....	6.661

MANDOS EMBRAGUE

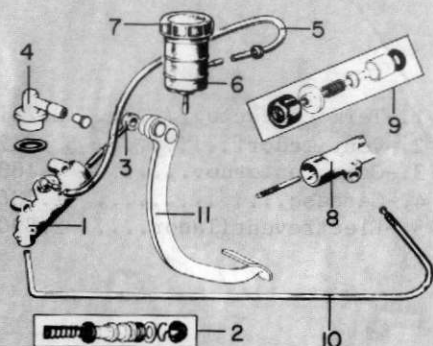

1.-Bomba embrague.....	2.127
2.-Juego reparación.....	262
3.-Varilla bomba.....	669
4.-Racor bomba.....	92
5.-Tubo bomba.....	161
6.-Depósito líquido.....	84
7.-Tapón depósito.....	44
8.-Bombín embrague.....	2.006
9.-Juego reparación.....	410
10.-Tubo bombín.....	568
11.-Pedal.....	1.164

EMBRAGUE

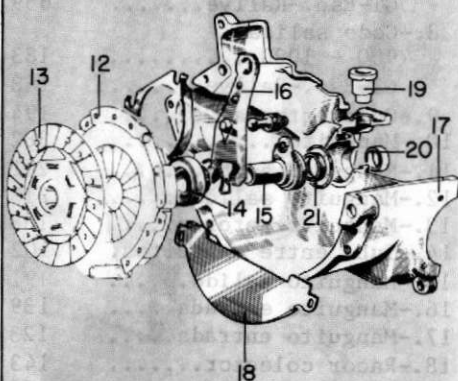

12.-Mecan. embrague:	
900 - 1000.....	4.664
GT-Esp.-Rallye.....	6.118
13.-Disco embrague:	
900 - 1000.....	2.216
GT-Esp.-Rallye.....	3.238
14.-Collarín.....	1.577
15.-Cufa collarín.....	854
16.-Horquilla embrague...	403
17.-Envolvente.....	9.880
18.-Guardapolvo.....	206
19.-Respiradero.....	242
20.-Casquillo.....	143
21.-Retén árbol.....	47

CAJA DE CAMBIOS

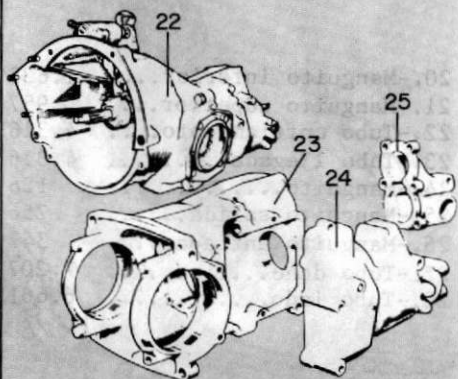

22.-Caja cambios:	
900.....	66.421
1000.....	126.147
23.-Carcasa cambio.....	11.296
24.-Tapa con hoquilla....	18.806
25.-Tapa delantera.....	2.942

CAJA DE CAMBIOS

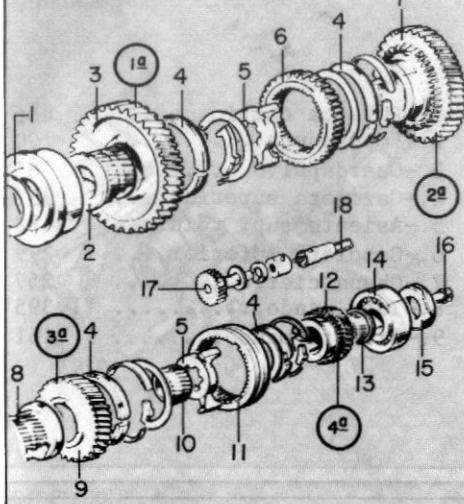

1.-Rodamiento tren.....	2.208
2.-Casquillo primario...	1.148
3.-Piñón 1ª.....	8.673
4.-Anillo sincronizado..	806
5.-Buje desplazable.....	1.626
6.-Desplazable 1ª-2ª-M.A	5.338
7.-Piñón 2ª.....	6.473
8.-Casquillo piñón 2ª...	965
9.-Piñón 3ª.....	9.112
10.-Casquillo piñón 3ª...	755
11.-Despl. 3ª - 4ª.....	2.290
12.-Piñón 4ª.....	9.112
13.-Casquillo piñón 4ª...	962
14.-Rodam. árbol secund..	549
15.-Tuerca piñón ataque..	155
16.-Piñón tacómetro.....	342
17.-Piñón ataque.....	525
18.-Cable c/kms.....	1.638

CAJA DE CAMBIOS

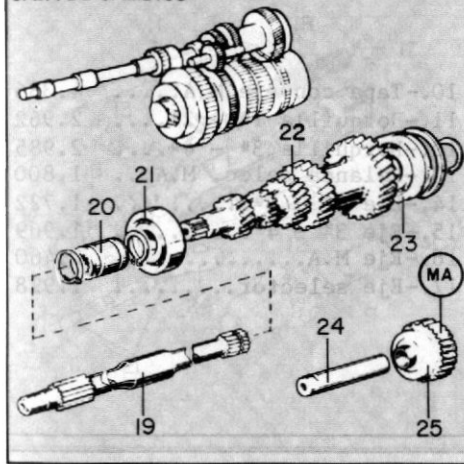

19.-Arbol embrague.....	6.748
20.-Manguito árbol.....	757
21.-Rodamiento.....	2.334
22.-Arbol primario:	
900 - 1000.....	8.925
900 Especial.....	6.205
23.-Rodamiento del.....	S/P
24.-Eje piñón M.A.....	1.178
25.-Piñón M.A.....	5.403

DIFERENCIAL

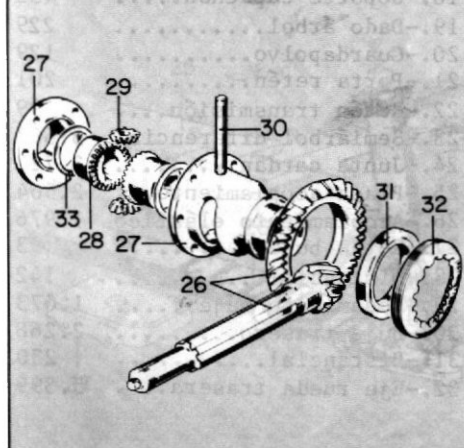

26.-Grupo cónico:	
900.....	16.355
1000.....	18.725
GT-Esp.-Rallye.....	18.091
27.-Caja satélites.....	7.900
28.-Piñón planetario.....	3.868
29.-Piñón satélites.....	2.490
30.-Eje caja satélites...	842
31.-Rodamiento diferenc..	1.824
32.-Tuerca reglaje.....	617
33.-Arandela reglaje.....	230

PALANCA DE CAMBIO

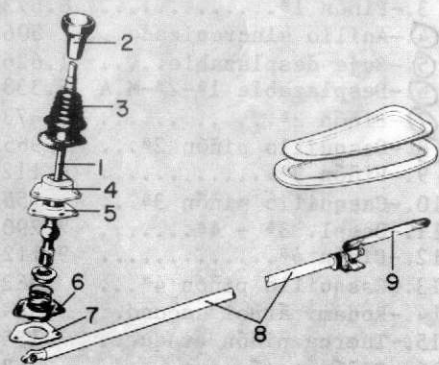

1.-Palanca cambio.....	886
2.-Empuñadura.....	160
3.-Guardapolvo.....	65
4.-Cazoleta superior....	352
5.-Asiento sup. rótula..	88
6.-Cazoleta inferior....	299
7.-Chapa cierre.....	257
8.-Tubo mando.....	1.395
9.-Bieleta mando.....	161

HORQUILLAS

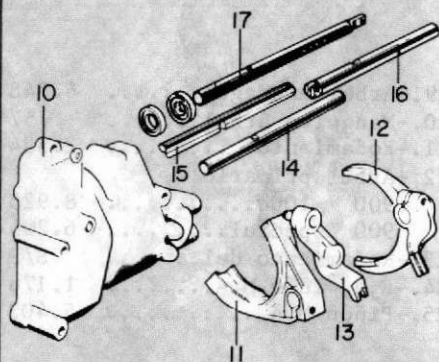

10.-Tapa con eje M.A.....	4.386
11.-Horquilla 1ª - 2ª....	2.962
12.-Horquilla 3ª - 4ª....	2.985
13.-Palanca selec. M.A...	1.800
14.-Eje 1ª - 2ª.....	1.722
15.-Eje 3ª - 4ª.....	1.969
16.-Eje M.A.....	2.460
17.-Eje selector.....	1.928

TRANSMISION

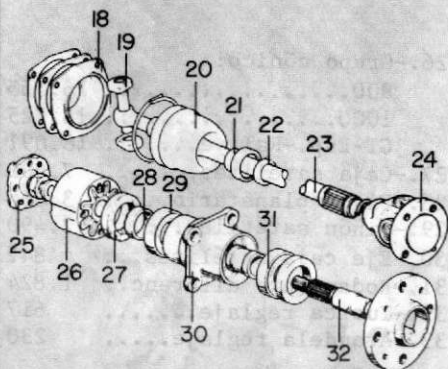

18.-Soporte capuchón....	433
19.-Dado árbol.....	229
20.-Guardapolvo.....	129
21.-Porta retén.....	201
22.-Retén transmisión....	99
23.-Semiárbol diferencial	5.667
24.-Junta cardan.....	3.723
25.-Placa acoplamiento...	2.564
26.-Acoplamiento elástico	1.976
27.-Retén buje.....	93
28.-Distancial.....	142
29.-Rodamiento buje....	1.073
30.-Buje trasero.....	2.268
31.-Distancial.....	230
32.-Eje rueda trasera....	5.399

DIRECCION

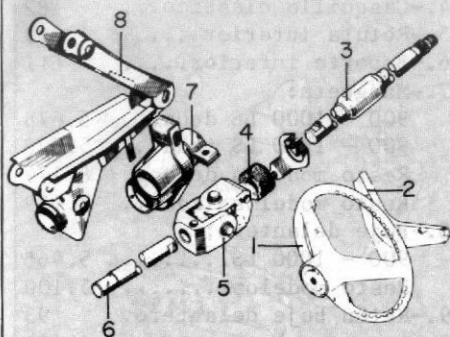

1.-Volante dirección:	
900 - 1000.....	2.802
GT-Esp.-Rallye.....	S/P
2.-Almohadilla.....	455
3.-Arbol superior.....	2.199
4.-Casquillo caña.....	473
5.-Junta cardan.....	680
6.-Arbol inferior.....	2.011
7.-Soporte árbol.....	3.233
8.-Soporte dirección....	1.119

DIRECCION

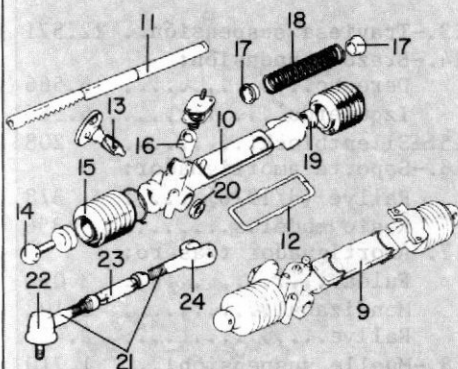

9.-Conj. caja dirección.	28.491
10.-Carcasa dirección....	3.266
11.-Cremallera.....	4.205
12.-Tapa caja dirección..	251
13.-Cruceta dirección....	7.582
14.-Articulación.....	1.278
15.-Fuelle dirección.....	251
16.-Vástago.....	251
17.-Copela muelle.....	196
18.-Muelle recuperación..	80
19.-Casquillo caja.....	335
20.-Rodamiento piñón....	441
21.-Barra mando.....	3.252
22.-Rótula dirección.....	775
23.-Manguito reglaje....	358
24.-Barra unión.....	2.438

SUSPENSION DELANTERA

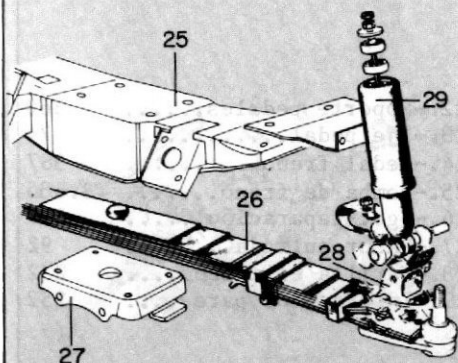

25.-Trav. suspensión....	9.975
26.-Ballesta delantera...	6.449
27.-Placa inferior.....	776
28.-Soporte delantero....	1.898
29.-Amortiguador delant.:	
Meldizabal.....	2.102
Fulda.....	3.052

SUSPENSION DELANTERA

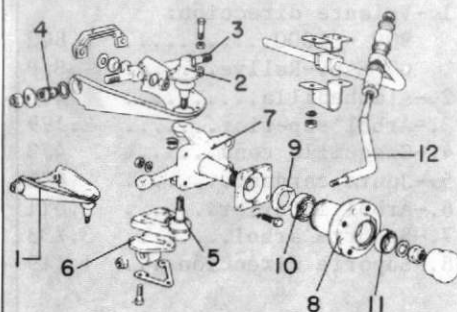

1.-Brazo superior.....	3.570
2.-Rótula brazo.....	939
3.-Eje brazo inferior...	1.342
4.-Casquillo elástico...	182
5.-Rótula inferior.....	1.679
6.-Soporte inferior.....	611
7.-Mangueta:	
900 - 1000 LS dcha...	5.678
900 - 1000 LS izda...	5.678
Resto modelos dcha...	8.179
Resto modelos izda...	8.179
8.-Buje delantero:	
900 - 1000 LS.....	5.465
Resto modelos.....	5.100
9.-Retén buje delantero.	93
10.-Rodamiento interior..	1.073
11.-Rodamiento exterior..	7.067
12.-Tirante barra.....	760

SUSPENSION TRASERA

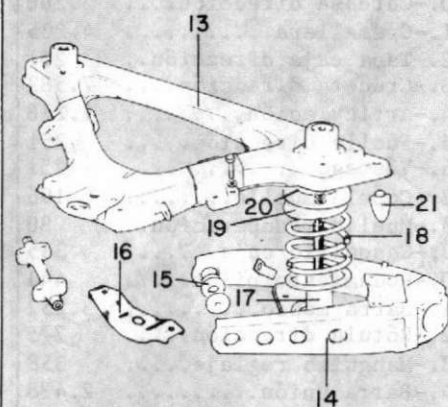

13.-Traviesa suspensión..	22.571
14.-Brazo suspensión:	
Derecho.....	6.566
Izquierdo.....	6.566
15.-Silentblock.....	208
16.-Soporte amortiguador:	
Rallye (d/1976).....	378
Resto modelos.....	356
17.-Amortiguador trasero:	
Fulda.....	2.020
Mendizabal.....	2.102
Rallye.....	2.453
18.-Muelle suspensión...	1.710
19.-Aislante muelle.....	195
20.-Placa apoyo.....	167
21.-Tope elástico.....	70

BOMBA FRENOS SIMPLE

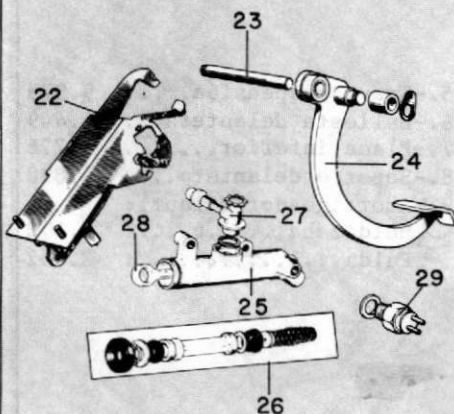

22.-Soporte pedales.....	360
23.-Eje pedal.....	74
24.-Pedal freno.....	387
25.-Bomba de freno.....	3.685
26.-Jgo. reparación.....	311
27.-Racor entrada.....	92
28.-Varilla cilindro.....	222
29.-Interruptor pare.....	252

BOMBA FRENOS DOBLE

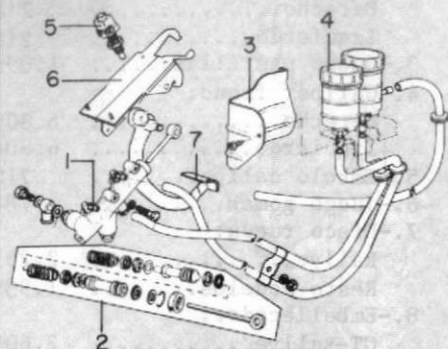

1.-Bomba frenos:	
900 - 1000.....	4.750
Rallye.....	4.496
2.-Jgo. reparación.....	571
3.-Protector.....	146
4.-Depósito.....	S/P
5.-Interruptor pare.....	289
6.-Soporte pedales.....	1.736
7.-Pedal freno.....	435

INSTALACION FRENOS TAMBOR

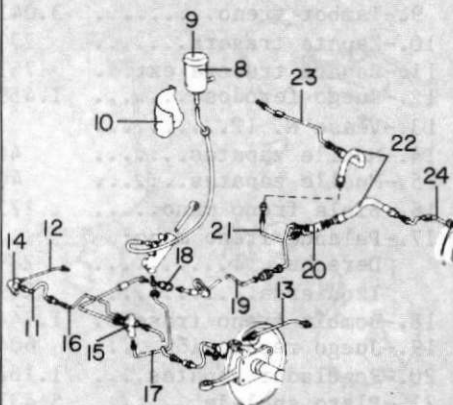

8.-Depósito.....	84
9.-Tapón depósito.....	44
10.-Protector.....	S/P
11.-Latiguillo.....	384
12.-Tubo a calíper.....	166
13.-Tubo a calíper.....	166
14.-Tubo tubería.....	112
15.-Racor 4 vías.....	193
16.-Tubo freno.....	74
17.-Tubo freno.....	60
18.-Racor 2 vías.....	74
19.-Tubo central.....	129
20.-Racor 3 vías.....	250
21.-Tubo a latiguillo...	123
22.-Latiguillo trasero...	380
23.-Tubo de freno.....	105
24.-Tubo latiguillo.....	105

INSTALACION FRENOS DISCO

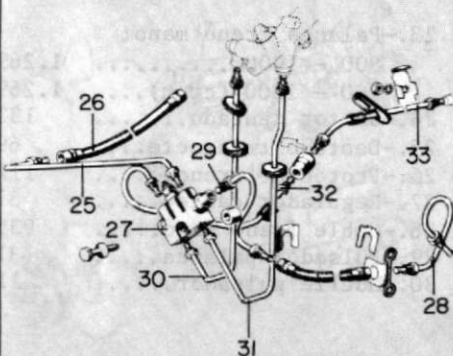

25.-Tubo racor.....	96
26.-Latiguillo delantero.	384
27.-Racor válvula.....	4.054
28.-Tubo racor.....	166
29.-Tubo racor.....	96
30.-Tubo bomba.....	70
31.-Tubo racor-bomba....	81
32.-Tubo válvula-racor...	135
33.-Tubo trasero.....	112

FRENOS DELANTEROS

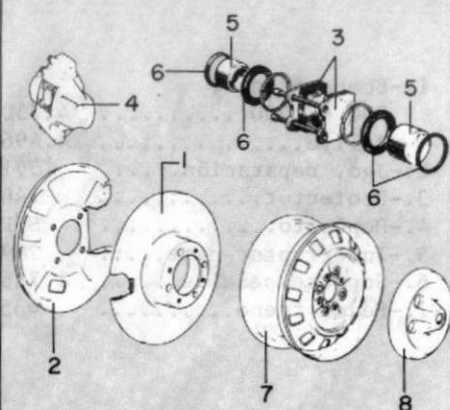

1.-Disco freno.....	2.297
2.-Guardapolvo:	
Derecho.....	218
Izquierdo.....	218
3.-Juego pastillas.....	1.095
4.-Caliper freno:	
Derecho.....	6.808
Izquierdo.....	6.808
5.-Embolo caliper.....	710
6.-Juego gomas.....	788
7.-Disco rueda:	
Rallye.....	2.255
Resto modelos.....	1.938
8.-Embellecedor:	
GT-Rallye.....	2.600
Resto modelos.....	629

FRENOS TRASEROS

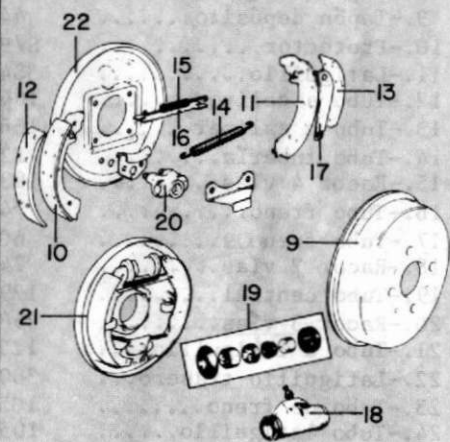

9.-Tambor freno.....	3.041
10.-Zapata trasera.....	773
11.-Zapata trasera ext...	751
12.-Juego ferodos.....	1.459
13.-Véase N. 12.....	
14.-Muelle zapatas.....	40
15.-Muelle zapatas.....	40
16.-Biela freno mano....	172
17.-Palanca freno mano:	
Derecha.....	289
Izquierda.....	289
18.-Bombín freno trasero.	1.744
19.-Juego reparación....	604
20.-Regulador zapatas....	1.168
21.-Plato anclaje.....	5.433
22.-Plato desnudo.....	589

FRENO DE MANO

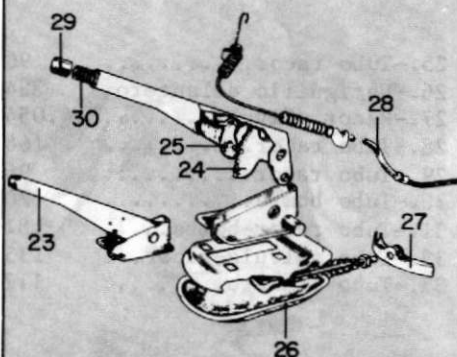

23.-Palanca freno mano:	
900 - 1000.....	1.269
900 - 1000 (crom)....	1.269
24.-Sector dentado.....	133
25.-Dentado trinquete....	69
26.-Protector freno.....	112
27.-Regulador cable.....	37
28.-Cable freno mano....	935
29.-Pulsador palanca....	31
30.-Muelle pulsador.....	11

ENCENDIDO

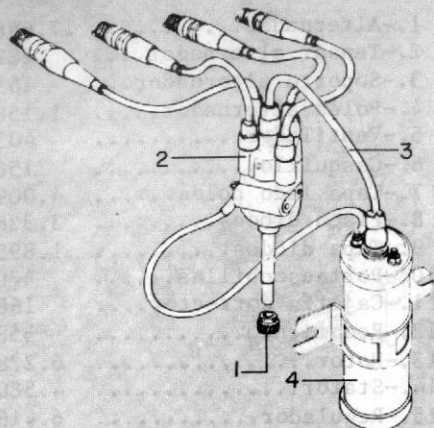

1.-Piñón distribución...	1.434
2.-Distribuidor:	
Femsa.....	7.936
Bosch.....	6.743
3.-Juego cables.....	436
4.-Bobina encendido....	2.479

DESPIECE DISTRIBUIDOR

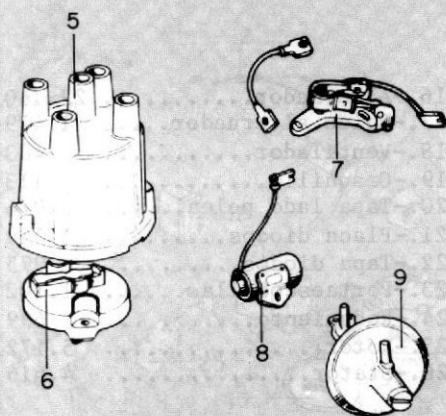

5.-Tapa distribuidor:	
Femsa.....	475
Bosch.....	475
6.-Rotor:	
Femsa.....	332
Bosch.....	306
7.-Juego platinos:	
Femsa.....	368
Bosch.....	373
8.-Condensador:	
Femsa.....	306
Bosch.....	383
9.-Depresor:	
Femsa.....	1.128
Bosch.....	873

DINAMO

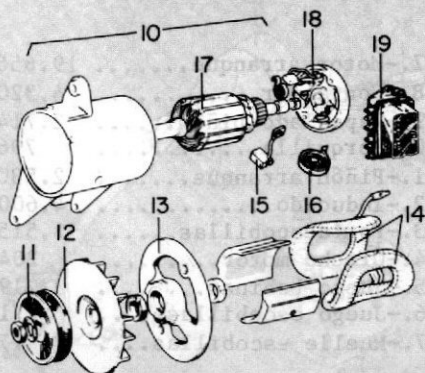

10.-Dinamo Femsa.....	18.937
11.-Polea dinamo.....	1.153
12.-Ventilador.....	556
13.-Tapa lado polea.....	1.959
14.-Inductoras.....	3.744
15.-Juego escobillas.....	179
16.-Muelle escobillas....	81
17.-Inducido dinamo.....	3.948
18.-Tapa portaescobillas.	1.556
19.-Regulador:	
Femsa.....	4.932
Bosch.....	3.305

ALTERNADOR FEMSA

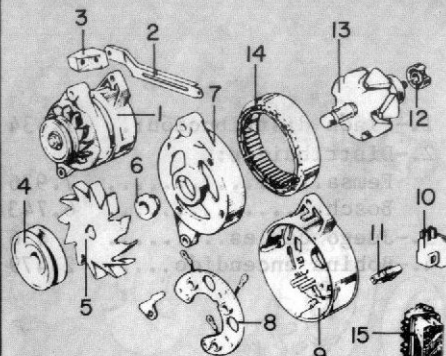

1.-Alternador.....	17.646
2.-Tensor alternador....	282
3.-Soporte alternador...	165
4.-Polea alternador.....	1.158
5.-Ventilador.....	403
6.-Casquillo.....	156
7.-Tapa lado polea.....	4.009
8.-Placa diodos.....	3.326
9.-Tapa diodos.....	1.893
10.-Portaescobillas.....	470
11.-Cajetín corrector....	168
12.-Rodamiento.....	358
13.-Rotor.....	6.228
14.-Stator.....	4.580
15.-Regulador.....	6.416

ALTERNADOR BOSCH

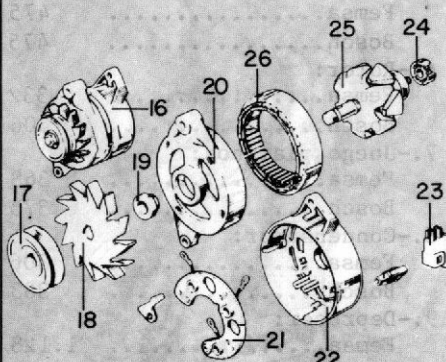

16.-Alternador.....	22.160
17.-Polea alternador.....	1.479
18.-Ventilador.....	403
19.-Casquillo.....	113
20.-Tapa lado polea.....	2.076
21.-Placa diodos.....	3.509
22.-Tapa diodos.....	975
23.-Portaescobillas.....	1.102
24.-Rodamiento.....	699
25.-Rotor.....	5.172
26.-Stator.....	4.616

MOTOR ARRANQUE FEMSA

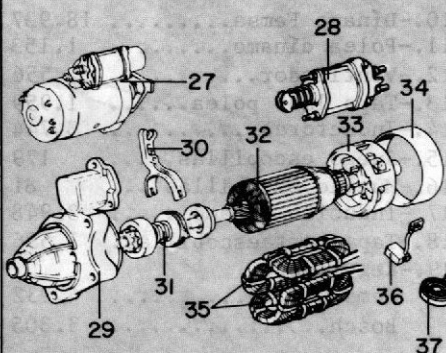

27.-Motor arranque.....	19.656
28.-Contactor.....	4.320
29.-Tapa lado piñón.....	2.714
30.-Horquilla.....	796
31.-Piñón arranque.....	2.530
32.-Inducido.....	4.600
33.-Portaescobillas.....	1.515
34.-Cincho motor.....	204
35.-Juego bobinas.....	3.219
36.-Juego escobillas.....	271
37.-Muelle escobillas....	77

MOTOR ARRANQUE BOSCH

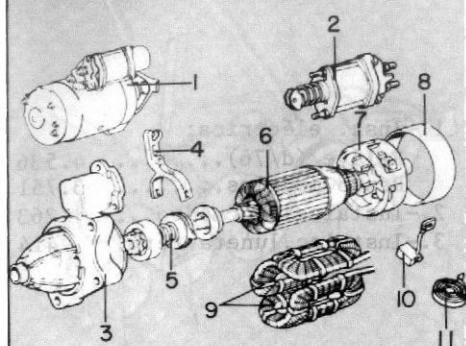

1.-Motor arranque.....	16.315
2.-Contactor.....	4.361
3.-Tapa lado piñón.....	2.086
4.-Horquilla.....	301
5.-Piñón arranque.....	3.122
6.-Inducido.....	6.141
7.-Portaescobillas.....	1.913
8.-Cincho motor.....	332
9.-Juego bobinas:	
Superior.....	1.454
Inferior.....	1.454
10.-Jgo. escobillas.....	459
11.-Muelle escobillas....	34

EQUIPO ELECTRICO

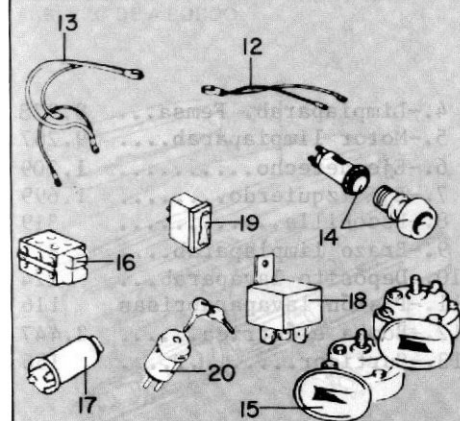

12.-Cable masa.....	151
13.-Cable positivo:	
En maletero.....	2.361
En motor.....	322
14.-Encendedor.....	800
15.-Claxon.....	1.241
16.-Caja fusibles.....	107
17.-Caja intermitencias..	743
18.-Relés:	
Claxon.....	512
Luna trasera térmica.	512
Faro larga distancia.	136
19.-Interruptores:	
Luna trasera térmica.	146
Limpiaparabrisas....	382
Luces.....	286
20.-Cont. antirrobo.....	2.770

EQUIPO ELECTRICO

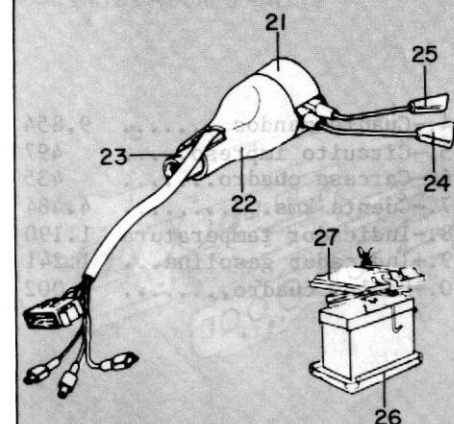

21.-Combinador luces:	
Desde 1976.....	4.629
Desde 1974.....	3.684
Hasta 1974.....	5.120
22.-Cuerpo inferior.....	297
23.-Tubo gufa.....	891
24.-Palanca mando luces..	635
25.-Palanca intermitenc..	436
26.-Tapa inferior:	
Hasta 1976.....	83
Desde 1976.....	117
27.-Tapa superior:	
Hasta 1976.....	183
Desde 1976.....	230

INSTALACION ELECTRICA

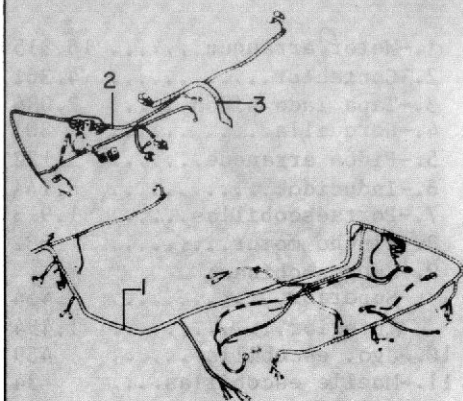

1.-Inst. eléctrica:	
Rallye (d/76).....	4.536
Resto modelos.....	3.751
2.-Instalación cuadro...	263
3.-Instalac.luneta térm.	414

LIMPIAPARABRISAS

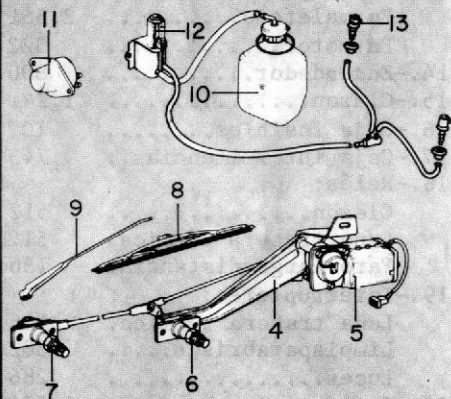

4.-Limpiaparab. Femsal...	8.978
5.-Motor limpiaparab....	9.267
6.-Eje derecho.....	1.209
7.-Eje izquierdo.....	1.699
8.-Escobilla.....	319
9.-Brazo limpiaparab....	811
10.-Depósito lavaparab...	124
11.-Pistón lavaparabrisas	116
12.-Bomba eléctrica.....	2.447
13.-Surtidor.....	156

CUADRO INSTRUMENTOS

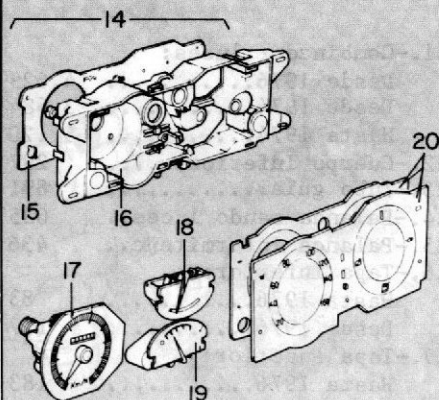

14.-Cuadro mandos.....	9.854
15.-Circuito impreso.....	497
16.-Carcasa cuadro.....	435
17.-Cuenta kms.....	4.484
18.-Indicador temperatura	1.190
19.-Indicador gasolina...	1.241
20.-Realce cuadro.....	1.002

CUADRO INSTRUMENTOS RALLYE

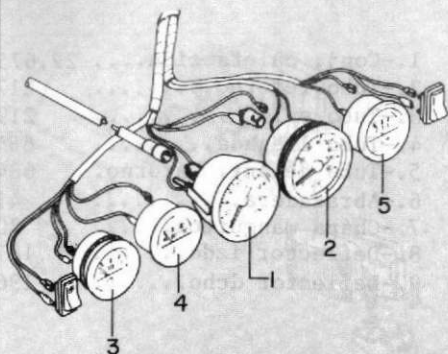

1.-Cuenta kms.:	
Rallye d/1976.....	4.982
Resto modelos.....	5.069
2.-Cuenta revoluciones:	
Rallye d/1976.....	10.337
Resto modelos.....	11.087
3.-Indicador gasolina:	
Rallye d/1976.....	2.989
Resto modelos.....	2.137
4.-Indicador temperat.:	
Rallye d/1976.....	2.989
Resto modelos.....	2.581
5.-Indic. presión aceite:	
Rallye d/1976.....	2.989
Resto modelos.....	2.833

TABLERO DE A BORDO

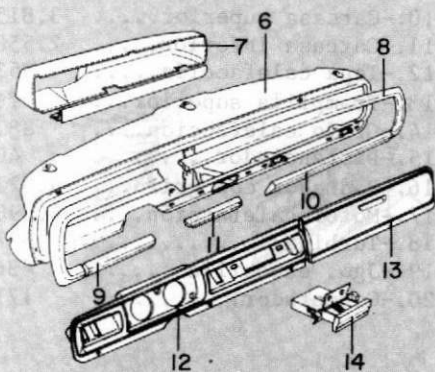

6.-Tablero instrumentos.	3.791
7.-Caja guantera.....	333
8.-Burlete superior.....	2.402
9.-Burlete inferior izd.	229
10.-Burlete inferior dch.	515
11.-Burlete inf. central.	229
12.-Embellecedor.....	S/P
13.-Tapa guantera.....	1.715
14.-Cenicero.....	S/P

TABLERO DE A BORDO RALLYE

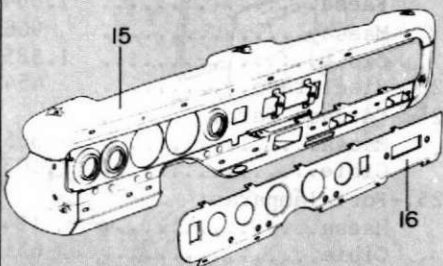

15.-Tablero instrumentos:	
Rallye d/1976.....	6.219
Resto modelos.....	13.098
16.-Embellecedor tablero:	
Rallye.....	227
Especial.....	811

CALEFACCION

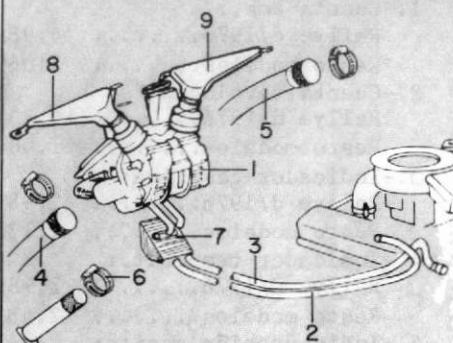

1.-Conj. calefacción....	22.675
2.-Tubo retorno.....	217
3.-Tubo salida.....	219
4.-Tubo llegada.....	684
5.-Tubo delant. retorno.	684
6.-Abrazadera.....	41
7.-Chapa manguitos.....	70
8.-Deflector izdo.....	187
9.-Deflector dcho.....	196

CALEFACCION

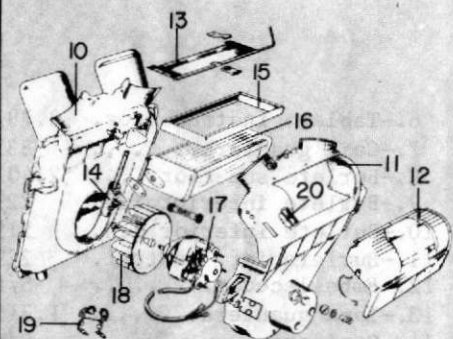

10.-Carcasa superior....	3.815
11.-Carcasa inferior....	2.558
12.-Tapa calefacción....	953
13.-Trampilla superior...	76
14.-Grifo calefacción....	883
15.-Distanciador.....	40
16.-Radiador con grifo...	4.322
17.-Motor calefacción....	4.098
18.-Turbina.....	307
19.-Jgo. escobillas.....	436
20.-Conmutador.....	171

FAROS HASTA 1976

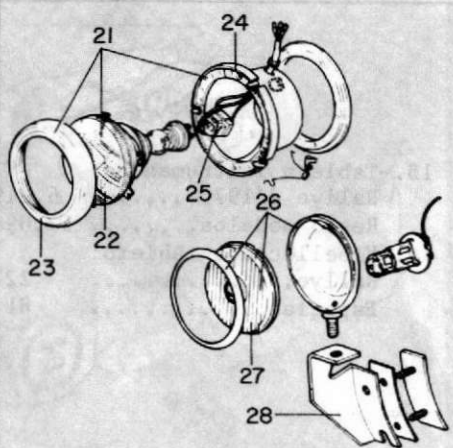

21.-Faro h/1976:	
Maesa.....	1.730
Faesa.....	4.004
Cibie.....	3.361
22.-Optica faro:	
Faesa.....	1.884
Maesa.....	968
Cibie.....	1.585
23.-Bisel faro.....	454
24.-Carcasa faro:	
Maesa.....	365
Cibie.....	1.103
25.-Portalámparas:	
Maesa.....	124
Cibie.....	631
26.-Faro larga distancia.	3.928
27.-Optica faro.....	2.317
28.-Soporte faro.....	56

FAROS DESDE 1976

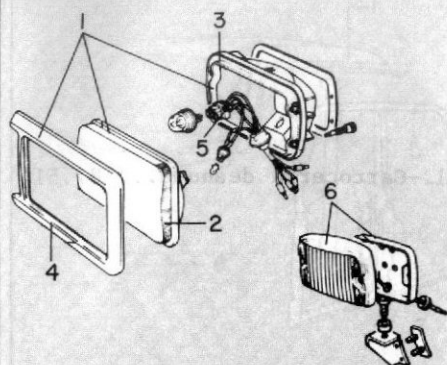

1.-Faro rectangular:	
Derecho.....	S/P
Izquierdo.....	S/P
2.-Optica faro.....	4.712
3.-Carcasa faro.....	1.022
4.-Bisel faro:	
Derecho.....	3.162
Izquierdo.....	3.162
5.-Portalámparas.....	797
6.-Faro larga distancia.	5.467

PILOTOS DELANTEROS

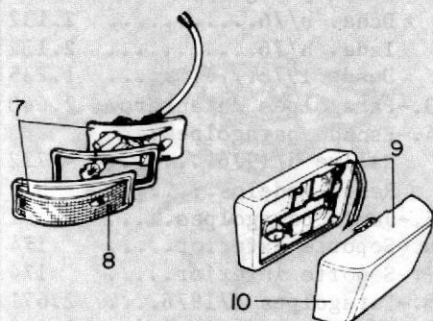

7.-Piloto delantero:	
Hasta 1976.....	1.718
Desde 1976 dcho.....	1.701
Desde 1976 izdo.....	1.701
8.-Tulipa piloto:	
Hasta 1976 dcha.....	871
Hasta 1976 izda.....	871
Desde 1976 dcha.....	808
Desde 1976 izda.....	808
9.-Plafón techo.....	343
10.-Tulipa plafón.....	39

PILOTOS TRASEROS

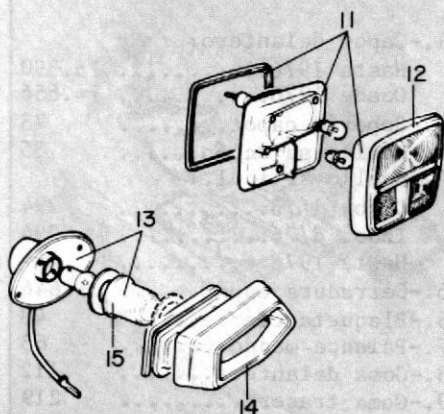

11.-Piloto trasero:	
Rallye dcho.....	1.416
Rallye izdo.....	1.416
Resto modelos dcho...	1.416
Resto modelos izdo...	1.416
12.-Tulipa piloto:	
Rallye dcha.....	804
Rallye izda.....	804
Resto modelos dcha...	804
Resto modelos izda...	804
13.-Piloto matrícula:	
900 - 1000.....	323
Rallye.....	263
14.-Aplique matrícula....	871
15.-Portalámparas:	
Hasta 1976.....	118
Desde 1976.....	233

CARROCERIA

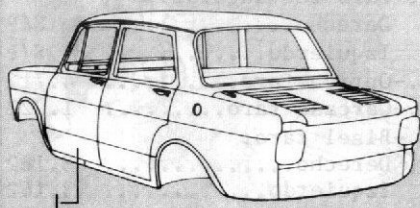

1.-Carrocería desnuda... 87.514

PARAGOLPES

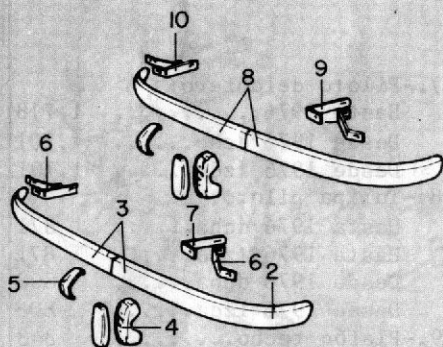

2.-Punta paragolpes:
 Dcha. h/76..... 2.132
 Izda. h/76..... 2.132
 Desde 1976..... 1.235
 3.-Paragolpes delantero. 2.640
 4.-Escudo paragolpes:
 Rallye d/1976..... 722
 Resto modelos..... S/P
 5.-Junta paragolpes..... 91
 6.-Soporte exterior..... 174
 7.-Soporte interior..... 174
 8.-Paragolpes d/1976.... 2.671
 9.-Soporte trasero izdo. 1.648
 10.-Soporte trasero dcho. 1.648

CAPOT DELANTERO

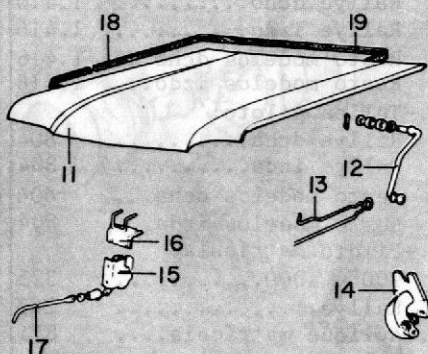

11.-Capot delantero:
 Hasta 1976..... 15.390
 Desde 1976..... 14.656
 12.-Soporte capot..... 73
 13.-Muelle sujeción..... 35
 14.-Cuello articular.:
 Dcho. d/76..... 294
 Izdo. d/76..... 294
 Hasta 1976..... 244
 15.-Cerradura capot..... 646
 16.-Plaqueta cierre..... 43
 17.-Palanca mando..... 63
 18.-Goma delantera..... 112
 19.-Goma trasera..... 219

TECHO Y LATERAL

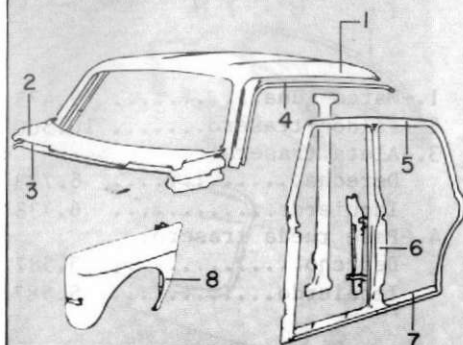

1.-Techo chapa.....	18.469
2.-Torpedo delantero....	4.788
3.-Travesaño.....	4.138
4.-Vierteaguas:	
Derecho.....	599
Izquierdo.....	599
5.-Marco puertas:	
Derecho.....	18.607
Izquierdo.....	18.607
6.-Pilar central:	
Derecho.....	4.737
Izquierdo.....	4.737
7.-Larguero:	
Derecho.....	1.231
Izquierdo.....	1.231
8.-Aleta delantera:	
Derecha.....	4.311
Izquierda.....	4.311

CONJUNTO DELANTERO

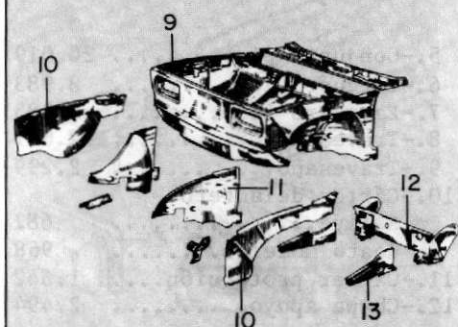

9.-Conj. delantero:	
Hasta 76.....	45.116
Desde 76.....	45.116
10.-Parte superior pase:	
Derecho.....	5.341
Izquierdo.....	5.341
11.-Pase rueda:	
Derecho.....	4.694
Izquierdo.....	4.694
12.-Travesaño delantero..	5.692
13.-Larguero delantero:	
Derecho.....	3.040
Izquierdo.....	3.040

FRENTE DELANTERO

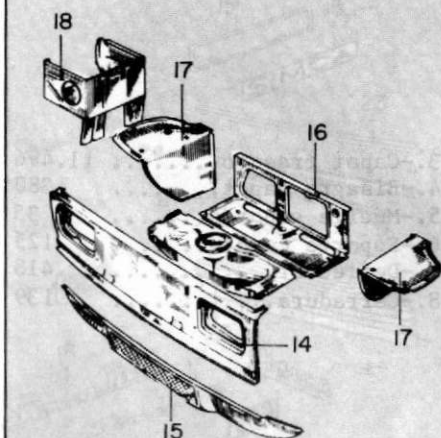

14.-Frente delantero:	
Hasta 76.....	3.933
Desde 76.....	6.714
15.-Faldón inferior:	
Hasta 76.....	3.840
Desde 76.....	3.427
16.-Fondo maletero:	
Hasta 76.....	930
Desde 76.....	1.030
17.-Piso:	
Hasta 76 dcho.....	1.301
Hasta 76 izdo.....	1.301
Desde 76 dcho.....	3.839
Desde 76 izdo.....	3.839
18.-Soporte batería:	
Hasta 1976.....	1.002
Desde 1976.....	949
19.-Cubeta rueda.....	4.130

FALDON Y ALETA TRASERA

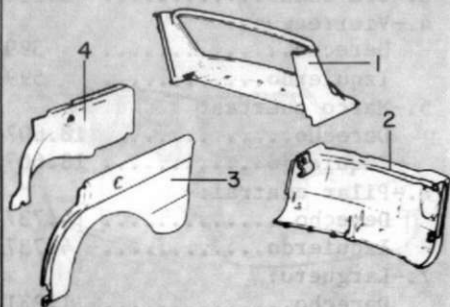

1.-Marco luna.....	9.475
2.-Faldón trasero.....	10.500
3.-Aleta trasera:	
Derecha.....	6.733
Izquierda.....	6.733
4.-Pase rueda trasero:	
Derecho.....	5.587
Izquierdo.....	5.587

PISO

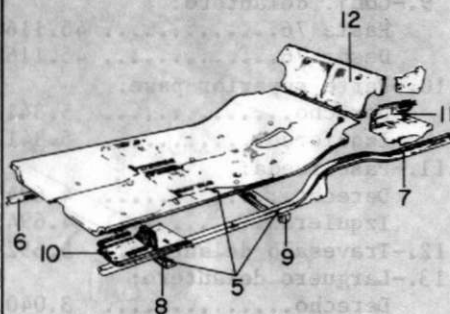

5.-Conjunto piso.....	20.019
6.-Larguero dcho.....	8.983
7.-Larguero izdo.....	8.983
8.-Travesaño.....	2.661
9.-Travesaño.....	2.299
10.-Cárter delantero:	
Rallye.....	682
Resto modelos.....	968
11.-Cárter protección....	1.642
12.-Chapa apoyo.....	2.494

CAPOT TRASERO

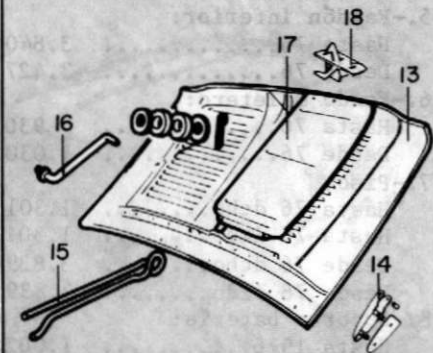

13.-Capot trasero.....	11.496
14.-Bisagra capot.....	380
15.-Muelle soporte.....	35
16.-Soporte capot.....	125
17.-Deflector.....	418
18.-Cerradura.....	139

LUNAS

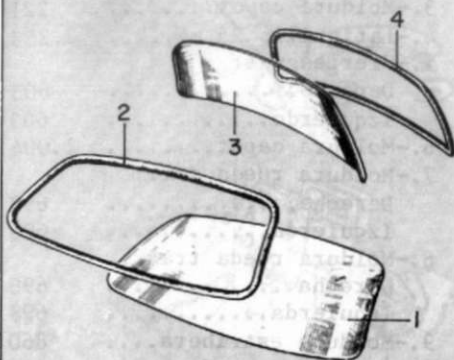

1.-Luna parabrisas:	
Blanca.....	2.561
Color.....	4.384
2.-Goma parabrisas.....	951
3.-Luna trasera:	
Blanca.....	2.299
Color.....	1.894
Térmica blanca.....	3.988
Térmica color.....	3.945
4.-Goma luna trasera....	861

EMBELLECEDORES 1.000

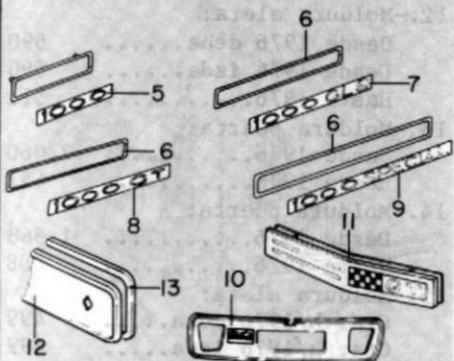

5.-Monograma 1000.....	36
6.-Soporte anagrama....	55
7.-Anagrama 1000 GLS....	41
8.-Anagrama 1000 GT....	72
9.-Anagrama 1000 Esp....	41
10.-Embelledor tablero.	6.536
11.-Embellec. frente GT..	372
12.-Placa matrícula.....	1.748
13.-Goma placa.....	26

EMBELLECEDORES 900

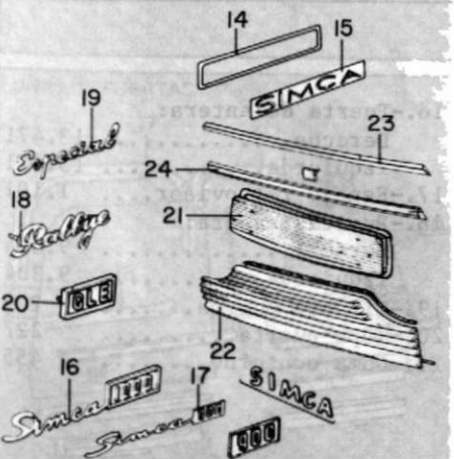

14.-Soporte monograma....	41
15.-Monograma SIMCA.....	71
16.-Monog. SIMCA 1000....	373
17.-Monog. SIMCA 900....	260
18.-Emblema Rallye.....	70
19.-Monograma Especial...	S/P
20.-Anagrama GLS.....	72
21.-Rejilla delantera....	6.054
22.-Rejilla delantera:	
Desde 1975.....	2.538
Hasta 1975.....	2.043
23.-Moldura superior....	142
24.-Moldura inferior....	163